







## HAKKIMIZDA

1972 yılından bu yana faaliyet gösteren firmamız, 46 yılı aşkın bir sürenin eseri olan tecrübesini babadan oğulla taşıyarak üzerine kattığı dinamik yapısını yeni projelerle güçlendirerek piyasada önemli bir yere sahip olmuştur. Bunda en büyük paya sahip olan yeni projemiz Türkiye'de de bir ilkin eseri olan minik tir projesidir.

Bunların yanı sıra konteynir römorku, ışık kuleleri, jeneratör römorkları NATO tipi askeri römorklar ve özel amaçlı römorklar için de kalitemizden kesinlikle ödün vermediğimiz bir anlayış ile 10.000 m<sup>2</sup> alanda üretimine devam ediyoruz. Ayrıca yedek parça desteğimizle de müşterilerimizi memnun etme çabası içerisindeyiz. Bu yapılan tüm işleri Türkiye distribütörlüğünü de üstlendiğimiz birçok ithal markalarla da destekliyoruz. İtalyan markası olan mono blok olan WINGAMM karavan markasını da Türkiye ile buluşturmaktan gurur duyar.

Firmamız, üretim ve hizmet alanlarında müşteri memnuniyetini en üst düzeyde tutma hedefiyle hareket etmektedir. Eroğlu Treyler Römork San. ve Tic. A.Ş deneyimli ve uzman kadrosu kalite ve güven prensipleri doğrultusunda müşterilerine her zaman en iyi hizmeti sunmaya çalışmaktadır.

Ayrıca firmamız 2010 yılından bu yana almış olduğu O1, O2, O3 ve O4 araç tip onay belgeleri ile üretimine profesyonel olarak AB standartlarında römork imalatına devam etmektedir.

## ABOUT US

Our company, which has been operating since 1972, has an important place in the market by strengthening its dynamic structure with new projects by carrying the experience of over 46 years of work from father to son.

New project which has the largest share in this success is our little piece of tar project, which is also a first in Turkey.

In addition to these, we continue production of 10.000 m<sup>2</sup> area with an understanding that we never compromise our container trailers, light towers, generator trailers, NATO type military trailers and special purpose trailers. We are also in an effort to satisfy our customers with our spare parts support. This made all the work we have undertaken the distributorship in Turkey, we also support the many imported brands.

WINGAMM caravan mono block with the Italian brand is proud to introduce the brand to Turkey.

Our company acts with the goal of keeping customer satisfaction at the highest level in production and service fields.

Eroğlu Treyler Römork San. ve Tic. A.Ş experienced and expert staff always try to provide the best service to the customers in line with the principles of quality and trust.

We are also continuing to produce trailers in EU standards professionally in production with O1, O2, O3 and O4 vehicle type approval documents which our company has taken since 2010.

# EROĞLU TREYLER

© /erogluromork | bilgi@romork.com.tr | www.romork.com.tr



90 312 385 46 89

© /erogluromork | bilgi@romork.com.tr | www.romork.com.tr

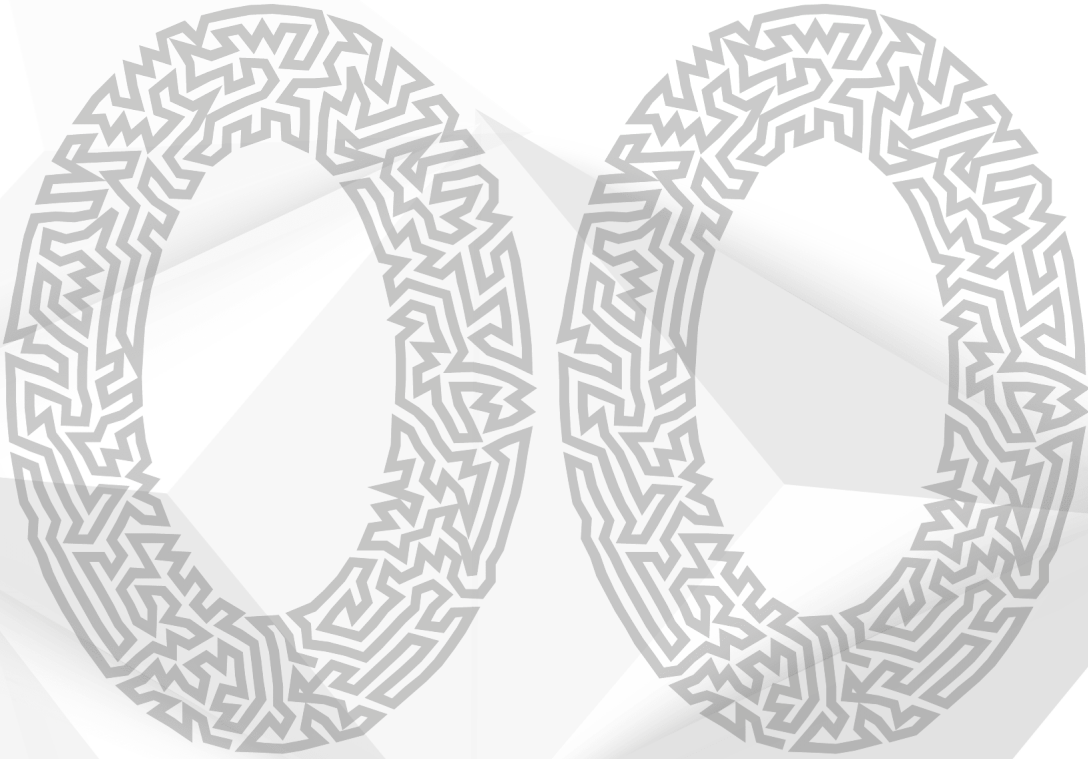

# INTRO

**Lowbed / Lowbed**

**Araç Taşıma Yarı Römork / Car Carrier Semi Trailer**

**Açık Kasa ve Sal Römork / Open Top and Platform Semi Trailer**

**Konteyner taşıyıcı / Container Carrier Semi Trailer**

**Kamyon römork / Truck Trailer**

**Döner Dingil römork / Turn Table Trailer**

**Mini tır / Mini Trekker Trailer**

**Özel amaçlı Römorklar / Light Trailer**

**Askeri römork / Military Trailer**

**Jeneratör Römorku / Generator Trailer**

**Işık Kulesi / Light Towers**

**Belgeler / Homologation**



 90 312 385 46 89

 bilgi@romork.com.tr | [www.romork.com.tr](http://www.romork.com.tr)



**LOWBED**  
**GRUBU**

**LOWBED**

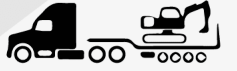

90 312 385 46 89

©/eroğluromork | bilgi@romork.com.tr | www.romork.com.tr

**EROĞLU**



# LOWBED LOWBED GRUBU

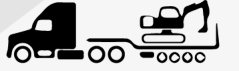

90 312 385 46 89

©/erogluromork | bilgi@romork.com.tr | www.romork.com.tr

EROĞLU

## ŞAŞİ:

. tozaltı ark kaynağı makinesi ile kaynak  
"I" kesitli 4 parça

## AKSLAR

2,3,4,5,6,7 adet 9-12-14-16 ton kapasiteli dingil  
kullanım

## SÜSPANSİYON

Parabolik çift katlı Z makaslar, Duvarcılık  
makas,

## ÖN AKS KALDIRMA

• Kabinin kontrollü ön aksı  
kaldırma sistemi

## LASTİKLER VE JANTLAR

235/75 R 17,5  
245/70 R 17,5  
• 295/60 R 22,5  
• 12 R 22,5  
315/80 R 22,5

## ELEKTRİKLİ EKİPMAN

• SAE standartları ve Tuv genel  
yönetmeliğe uygundur  
• Araçtan 7 pinli soket ile elektrik alınır.  
• Arka park, dur, sinyal, plakalı  
römork reflektörleri ve yanlarda turuncu uyarı mevcuttur

## FREN SİSTEMİ

EC Standartlarına göre 71/320 / ewg ff fren  
sistemi.  
• Otomatik fren circırları, servis freni bölmeleri.  
EBS 2S / 2M - 4S / 2M- 4S / 3M ve devrilmeye karşı  
sistem RSS (Denge Kontrolü) sağlar  
Sistem).

## KING-PIN

• DIN 74080 standardında 2 "veya  
3 " çelik dingil pimi kullanılmıştır

## DESTEK AYAKLARI

• Önde: 24 ton Mekanik römork ayakları  
• Arkada: Manuel destek ayakları

## ARKA RAMPA

160 NPU'dan yapılmıştır, Hava-Hidrolik  
pistonlu arka ayaklar

## TABAN

• yanlar; tekerlek üstleri elmas şeklindedir ve  
parke döşemeceliği

## BOYA

• Şase ve üst yapı Yıkama + Kuşlama +  
2 + 1 kat Akrilik Boya ile boyanmaktadır.

## RENK

• RAL KODU

## STANDART AKSESUARLAR

genişleyen parantezler (300 + 300 mm)  
bağlama halkalarını yükleyin

1 x takım dolabı (deveboynu altında)  
• 2 bisiklet rayı  
1 x Lastik montajı ve tutucusu  
• 1 x 60 lt kapasiteli plastik su deposu

## OPSİYONEL ÖZELLİKLER

Lowbed taşıma alanı havuz tipi  
Avrupa aks grubu ve her türlü ekipman  
Alüminyum jant  
Çift stepne taşıyıcı  
• Yangın söndürme dolabı ve tüpü  
• İsteğe bağlı lastik markası  
• İsteğe bağlı RAL renk kodları

## CHASSIS:

. welding with submerged arc welding machine  
4 pieces with "I" section

## AXLES

2,3,4,5,6,7 units of 9-12-14-16 ton capacity axle  
use

## SUSPENSION

Parabolic double-deck Z shears, Masonry  
scissors,

## FRONT AXLE LIFTING

• Cab's controlled front axle  
lifting system

## TIRES AND RIMS

235/75 R 17,5  
245/70 R 17,5  
• 295/60 R 22,5  
• 12 R 22,5  
315/80 R 22,5

## ELECTRICAL EQUIPMENT

• SAE standards and Tuv general  
complies with regulation  
• Electricity is taken from the vehicle with a  
7-pin socket.  
• Rear parking, stop, signal, with license plate  
trailer reflectors and orange warning on the  
sides exist

## BRAKE SYSTEM

71/320 / ewg ff brake according to EC Standards  
system.  
• Automatic brake ratchets, service brake  
chambers.  
EBS 2S / 2M - 4S/2M- 4S/3M and against tipping  
system provides RSS (Balance Control  
System).

## KING-PIN

• 2 "in DIN 74080 standard or  
3 " steel kingpin is used

## SUPPORT LEGS

• On the front: 24 tons Mechanical trailer legs  
• On the back: Manual support legs

## REAR RAMP

Made of 160 NPU, Air-Hydraulic  
rear legs with piston

## BASE

• sides; wheel tops are diamond-shaped sheet and  
hardwood flooring

## PAINT

• Chassis and superstructure Washing + Sandblast-  
ing +  
It is painted with 2 + 1 layers of Acrylic Paint.

## COLOR

• RAL CODE

## STANDARD ACCESSORIES

expanding brackets (300 + 300 mm)  
load lashing rings  
1 x tool cabinet (under gooseneck)  
• 2 bicycle rails  
1 x Tire mount and holder  
• 1 x 60 lt capacity plastic water tank

## OPTIONAL FEATURES

Lowbed transport area pool type  
European axle group and all kinds of equipment  
Aluminum rim  
Double spare wheel carrier  
• Fire extinguisher cabinet and tube  
• optional tire brand  
• Optional RAL color codes

# LOWBED GRUBU

# LOWBED



90 312 385 46 89

00/eroglumork | bilgi@romork.com.tr | www.romork.com.tr

EROĞLU

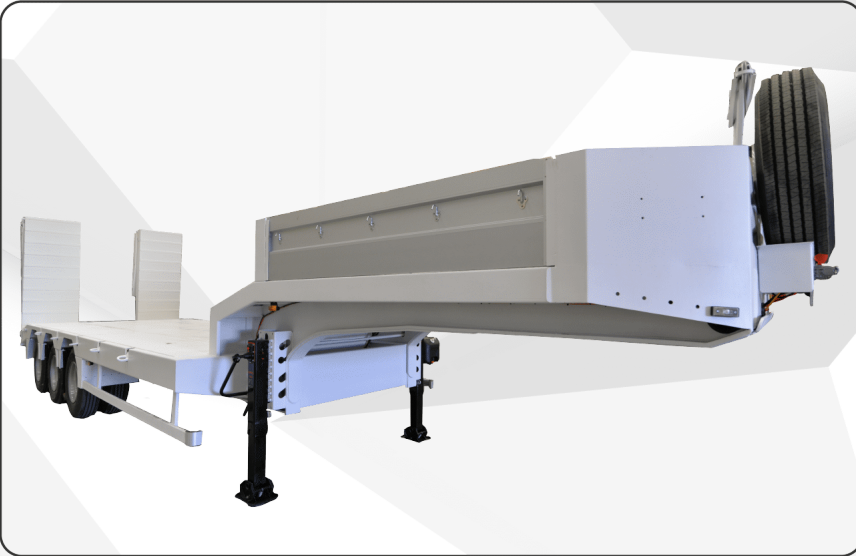



# LOWBED GRUBU

# LOWBED

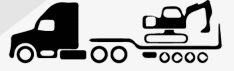

90 312 385 46 89

©/erogluromork | bilgi@romork.com.tr | www.romork.com.tr

EROĞLU

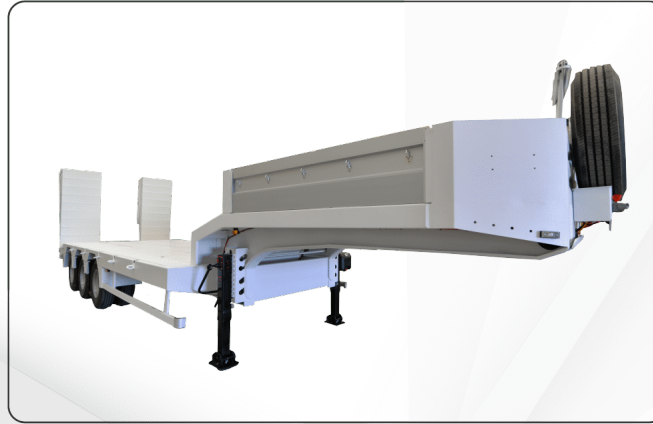

# ARAÇ TAŞIYICI YARI RÖMORK GRUBU

# CAR CARRIER SEMI TRAILER



90 312 385 46 89  
©/eroglurormork | bilgi@romork.com.tr | www.romork.com.tr

EROĞLU



# ARAÇ TAŞIYICI YARI RÖMORK GRUBU

## CAR CARRIER SEMI TRAILER



EROĞLU

© Eroglu Romork | bilgi@romork.com.tr | www.romork.com.tr

### ŞASI:

. tozaltı ark kaynağı makinesi ile kaynak  
"I" kesitli 4 parça

### AKSLAR

1-2-3 adet 9 ton kapasiteli dingil TRAX, BPW,  
SAF

### KAPASİTE

3,4 VE 6 ARAÇ TAŞIMA

### SÜSPANSİYON

Parabolik çift katlı Z makaslar,

### LASTİKLER VE JANTLAR

235/75 R 17,5  
245/70 R 17,5

### ELEKTRİKLİ EKİPMAN

- SAE standartları ve Tuv genel yönetmeliğe uygundur
- Araçtan 7 pinli soket ile elektrik alınır.
- Arka park, dur, sinyal, plakalı römork reflektörleri ve yanlarda turuncu uyarı mevcuttur

### FREN SİSTEMİ

71/320 / EC Standartlarına göre fren sistemi.

- Otomatik fren circırları, servis freni bölmeleri.
- EBS 2S / 2M

### HİDROLİK SİSTEM

5 Lİ KUMANDA KOLU , UZAKTAN KUMANDALI  
HİDROLİK ÜIİNÇ, UZAYAN PLARTFOMLAR

### KING-PIN

- DIN 74080 standardında 2 "veya

### DESTEK AYAKLARI

- Önde: 24 ton Mekanik römork ayakları
- Arkada: Manuel destek ayakları

### TABAN

- yanlar; tekerlek üstleri elmas şeklindedir ve parke döşemeciliği

### BOYA

- Şase ve üst yapı Yıkama + Kumlama + 2 + 1 kat Akriilik Boya ile boyanmaktadır.

### RENK

- RAL KODU

### STANDART AKSESUARLAR

- 1 x takım dolabı (deveboynu altında)
- 2 bisiklet rayı
- 1 x Lastik montajı ve tutucusu

### OPSİYONEL ÖZELLİKLER

#### Alüminyum jant

#### Çift stepne taşıyıcı

- Yangın söndürme dolabı ve tüpü
- İsteğe bağlı lastik markası
- İsteğe bağlı RAL renk kodları

### CHASSIS:

. welding with submerged arc welding machine  
4 pieces with "I" section

### AXLES

1-2-3 units of 9 ton capacity axle TRAX, BPW,  
SAF

### CAPACITY

3,4 AND 6 VEHICLE TRANSPORT

### SUSPENSION

Parabolic double layer Z shears,

### TIRES AND RIMS

235/75 R 17,5  
245/70 R 17,5

### ELECTRICAL EQUIPMENT

- SAE standards and Tuv general complies with regulation
  - Electricity is taken from the vehicle with a 7-pin socket.
- Rear parking, stop, signal, license plate trailer reflectors and orange warning on the sides

### BRAKE SYSTEM

Brake to 71/320 / EC Standards

- Automatic brake ratchets, service brake chambers.
- EBS 2S / 2M

### HYDRAULIC SYSTEM

5 LEVER CONTROL ARM, REMOTE CONTROLLED  
HYDRAULIC CRANE, EXTENDING PLARTFOMS

### KING-PIN

- 2 "in DIN 74080 standard or

### SUPPORT LEGS

- Front: 24 tons Mechanical trailer legs
- On the back: Manual support legs

### BASE

- sides; wheel tops are diamond shaped and parquet flooring

### PAINT

Chassis and superstructure Washing + Sandblasting +  
It is painted with 2 + 1 layers of Acrylic Paint.

### COLOR

- RAL CODE

### STANDARD ACCESSORIES

- 1 x tool cabinet (under gooseneck)
- 2 bicycle rails
- 1 x Tire mount and holder

### OPTIONAL FEATURES

- Aluminum rim
- Double spare wheel carrier
- Fire extinguisher and tube
- Optional tire brand
- Optional RAL color codes



**ARAÇ TAŞIYICI  
YARI RÖMORK  
GRUBU**

**CAR CARRIER  
SEMI TRAILER**



90 312 385 46 89

©/erogluromork | bilgi@romork.com.tr | www.romork.com.tr

**EROĞLU**



**ARAÇ TAŞIYICI  
YARI RÖMORK  
GRUBU**

**CAR CARRIER  
SEMI TRAILER**



90 312 385 46 89  
©/erogluromork | bilgi@romork.com.tr | www.romork.com.tr

**EROĞLU**

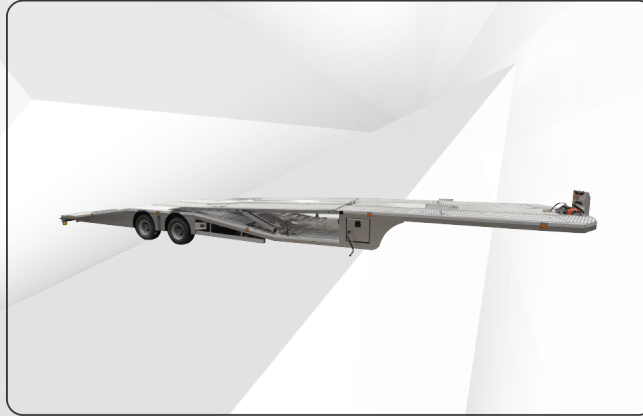
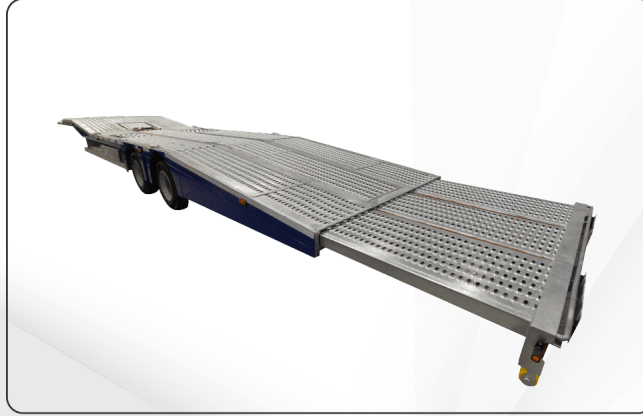



# AÇIK KASA VE SAL RÖMORK GRUBU

# OPEN TAB AND PLARTFORM SEMI TRAILER



90 312 385 46 89

©/erogluromork | bilgi@romork.com.tr | www.romork.com.tr

EROĞLU



# AÇIK KASA VE SAL RÖMORK GRUBU

# OPEN TAB AND PLARTFORM SEMI TRAILER



90 312 385 46 89

©/erogluromork | bilgi@romork.com.tr | www.romork.com.tr

EROĞLU

## ÜST YAPI

9.000mm-13.600mm ön düz çizgi, iç  
2550 mm genişlik 2440 mm

- Yanlarda ve kasada 4 veya 5 kapaklı monte
- Kapaklar dışarıdan bağlanır, 800mm-900mm dir
- Bir sıra metal levha ve bir sıra ahşaptan oluşan taban kapanacak
- Belli aralıklarla tabana yerleştirilen pres baskı "Z" traversler mevcuttur

## ŞASI

- Güçlendirilmiş "I" bölümü ana çerçevesi 120/12 5 mm sac, üst ve alt düz otomatik tozaltı ark kaynağı makinesi ile kaynak
- Bu şasiler bükülmeye karşı birbirine bağlıdır.

## AKSLAR

9 ve 12 ton kapasiteli 2 ve 3 dingil kullanıldı  
TSE normlarına uygun ağır fren balataları  
Servis fren kolları var

## SÜSPANSİYON

Parabolik çift katlı Z makaslar ve amortisörler

## ÖN AKS KALDIRMA

Kabinin kontrollü ön aksı kaldırma sistemi

## LASTİKLER VE JANTLAR

385/65 R22.5 lastik

## ELEKTRİKLİ EKİPMAN

- SAE standartları ve Tuv genel yönetmeliğe uygundur
  - Araçtan 7 pinli soket ile elektrik alınır.
- Arka park, dur, sinyal, plaka römork reflektörleri ve yanlarda turuncu uyarı aslında var

## FREN DONANIMI

EC Standartlarına göre 71/320 frensystem.  
• Otomatik fren circırları  
2S / 2M EBS

## KING-PIN

- DIN 74080 standardında veya DIN 74083'te 2 "veya 3" kral pim kullanıldı

## AYAKLAR

- Çift hızlı teleskopik, mekanik taşıma ayak, 24 ton kapasite

## BOYA

- Şase ve üst yapı Yıkama + Kumlama + 2 + 1 kat Akrilik Boya boyanmak

## RENK

Ral kodu

## STANDART AKSESUARLAR

Arka aks grubu lastiklerin kısmi kaplaması  
plastik çamurluklar  
2 sac metal alet kutusu  
Plastik su pazarı  
Sepetli 1 stepne taşıyıcı  
Alüminyum bisiklet kazası alanı  
• Takoz ve takoz pozisyonu

## OPSİYONEL ÖZELLİKLER

Avrupa aks grubu ve her türlü ekipman  
NPI Bölümü ana şasi kolları  
Temel MDF, sac metal ile tamamlanmış veya bitmiş kaplama  
Alüminyum jant  
Çift stepne taşıyıcı  
Kaldırma aksı  
Kaldırma tamponu  
• Yangın söndürücü ve tüp  
Kapaklara isteğe bağlı eklemeler  
İsteğe bağlı lastik markası  
İsteğe bağlı RAL renk kodları

## UPPER STRUCTURE

9.000mm-13.600mm front straight line, inner  
2550mm wide 2440mm  
• With 4 or 5 covers on the sides and case mounted  
• Covers are connected externally, 800mm-900mm dir  
• Base consisting of a row of metal sheets and a row of wood will close  
• Press placed on the base at certain intervals  
print "Z" sleepers are available

## CHASSIS

- Reinforced "I" section main frame 120/12 5 mm sheet metal, top and bottom flat with automatic submerged arc welding machine welding
- These chassis are interconnected against bending.

## AXLES

2 and 3 axles with 9 and 12 tons capacity is used  
Heavy brake pads in accordance with TSE norms  
There are service brake levers

## SUSPENSION

Parabolic double-deck Z shears and shock absorbers

## FRONT AXLE LIFT

Controlled front axle of the cabin lifting system

## TIRES AND RIMS

385/65 R22.5 tire

## ELECTRICAL EQUIPMENT

- SAE standards and Tuv general complies with regulation
  - Electricity is taken from the vehicle with a 7-pin socket.
- Rear parking, stop, signal, license plate trailer reflectors and orange warning on the sides actually exist

## BRAKE HARDWARE

71/320 frensystem according to EC Standards.  
• Automatic brake ratchets  
2S / 2M EBS

## KING-PIN

• 2 "or 3" king pin in DIN 74080 standard or DIN 74083 is used

## FEET

- Double speed telescopic, mechanical transport foot, 24 tons capacity

## PAINT

- Chassis and superstructure Washing + Sandblasting + 2 + 1 coat Acrylic Paint be painted

## COLOR

Ral code

## STANDARD ACCESSORIES

Partial coating of rear axle group tires  
plastic fenders  
2 sheet metal tool boxes  
Plastic water market  
1 spare wheel carrier with basket  
Aluminum bike crash site  
• Chock and chock position

## OPTIONAL FEATURES

European axle group and all kinds of equipment  
NPI Division main chassis arms  
Base MDF finished or finished with sheet metal covering  
Aluminum rim  
Double spare wheel carrier  
Lifting axle  
Lift buffer  
• Fire extinguisher and tube  
Optional additions to the covers  
Optional tire brand  
Optional RAL color codes



# AÇIK KASA VE SAL RÖMÖRK GRUBU

# OPEN TAB AND PLATFORM SEMI TRAILER



90 312 385 46 89

©/erogluromork | bilgi@romork.com.tr | www.romork.com.tr

EROĞLU





90 312 385 46 89

@erogluromork | bilgi@romork.com.tr | www.romork.com.tr

EROĞLU

# AÇIK KASA VE SİL RÖMORK GRUBU

# OPEN TAB AND PLARTFORM SEMI TRAILER



**KONTEYNER  
TAŐIYICI  
GRUBU**

**CONTAINER  
CARRIER  
SEMI TRAILER**



90 312 385 46 89

©O/erogluromork | bilgi@romork.com.tr | www.romork.com.tr

**EROĐLU**





# KONTEYNER TAŞIYICI GRUBU

# CONTAINER CARRIER SEMI TRAILER



90 312 385 46 89

@0/erogluromork | bilgi@romork.com.tr | www.romork.com.tr

EROĞLU

## CONTAINER CARRIER SEMI TRAILER

### ŞAŞI

- 20'30'40 '45 FEET Konteyner ölçüleri imalatı
- Güçlendirilmiş "I" bölümü ana şaşı 120/12 Mm üst ve alt düz otomatik tozaltı ark kaynağı makinesi ile kaynaklı
- Bu şaşılar bükülmeye karşı birbirine bağlıdır. uyuyanlar ile bağlanarak desteklenir

### TAŞINABİLİR KONTEYNER ÖLÇÜLERİ

- 1x45 '
- 1x40 '
- Ortada 1x30 'veya ortada 1x20'
- 2x20 '

### KONTEYNER KİLİDİ

- Kilitli 12 veya 14 parça

### AKSLAR

9-12 ton kapasiteli dingiller  
TSE normlarına uygun ve Ağır fren balataları  
Hizmet tipi fren kolları vardır

### SÜSPANSİYON

Parabolik çift katlı Z makaslar ve amortisörler

### ÖN AKS KALDIRMA

Kabinde ön aks kontrollü kaldırma sistemi

### LASTİKLER VE JANTLAR

385/65 R22,5 lastikler

## ELEKTRİKLİ EKİPMAN

- SAE standartları ve Tuv genel yönetmeliğe uygundur
- Araçtan 7 pinli soket ile elektrik alınır.
- Trafik uyarısı ve lambalar var
- Arka park, dur, sinyal, plaka lambaları
- römork reflektörleri ve yanlarda turuncu uyarı Lamba var

## FREN DONANIMI

- 71/320 / EC Standartlarına göre fren sistemi.
- Dikkat dağıtıcı 4, 2 otomatik fren circırları servis fren odaları.
  - 2S / 2M EBS

## KING-PIN

- DIN 74080 standardı, 2 "veya 3" çelik dingil pimi kullanılır.

## AYAKLAR

- Çift hızlı teleskopik, mekanik taşıma ayak, 24 ton taşıma kapasitesi

## BOYA

Kumlama sonrası şaşı ve üst yapı komple 2 + 1 kat epoksi astar ve akrilik boya

## RENK

Müşteri talebine göre belirtilecektir

## STANDART AKSESUARLAR

- Arka aks grubu lastiklerin kısmi kaplaması plastik çamurluklar
  - 1 sac metal alet kutusu
  - Plastik su deposu
  - Silindir stepne taşıyıcı
  - Alüminyum bisiklet kazası alanı
  - Takoz ve takoz konumu
- ## OPSİYONEL ÖZELLİKLER

- Avrupa aks grubu ve her türlü ekipman
- Alüminyum jant
- Yangın söndürme dolabı ve tüpü
  - İsteğe bağlı lastik markası
  - İsteğe bağlı RAL renk kodları

## CHASSIS

- 20'30'40 '45 FEET Container sizes manufacture
- Reinforced "I" section main chassis 120/12 With mm upper and lower flat automatic submerged arc welding machine is sourced
- These chassis are interconnected against torsion.
- supported by connecting with sleepers

## PORTABLE CONTAINER SIZES

- 1x45 '
- 1x40 '
- 1x30 'in the middle or 1x20' in the middle
- 2x20 '

## CONTAINER LOCK

- 12 or 14 pieces with lock

## AXLES

9 -12 tons capacity axles  
Brake linings in accordance with TSE norms and Heavy  
Has duty brake levers

## SUSPENSION

Parabolic double-deck Z shears and shock absorbers

## FRONT AXLE LIFTING

Front axle controlled in the cabin lifting system

## TIRES AND RIMS

385/65 R22,5 tires

## ELECTRICAL EQUIPMENT

- SAE standards and Tuv general complies with regulation
- Electricity is taken from the vehicle with a 7-pin socket.
- Traffic warning and have lamps
- Rear parking, stop, signal, license plate lights
- trailer reflectors and orange warning on the sides
- Has lamps

## BRAKE HARDWARE

- 71/320 / brake according to EC Standards system.
- Automatic brake ratchets, 4 with distractions, 2 service brake chambers.
  - 2S / 2M EBS

## KING-PIN

- DIN 74080 standard, 2 "or 3" steel kingpin is used.

## FEET

- Double speed telescopic, mechanical transport feet, 24 tons carrying capacity

## PAINT

Chassis and superstructure after sandblasting complete 2 + 1 coat of epoxy primer and acrylic paint

## COLOR

Will be specified according to customer request

## STANDARD ACCESSORIES

- Partial covering of rear axle group tires plastic fenders
  - 1 sheet metal tool box
  - Plastic water tank
  - Roller spare wheel carrier
  - Aluminum bike crash site
  - Chock and chock location
- ## OPTIONAL FEATURES
- European axle group and all kinds of equipment
- Aluminum rim
- Fire extinguisher cabinet and tube
  - Optional tire brand
  - Optional RAL color codes

**KONTEYNER  
TAŞIYICI  
GRUBU**

**CONTAINER  
CARRIER  
SEMI TRAILER**



90 312 385 46 89

©0/erogluromork | bilgi@romork.com.tr | www.romork.com.tr

**EROĞLU**

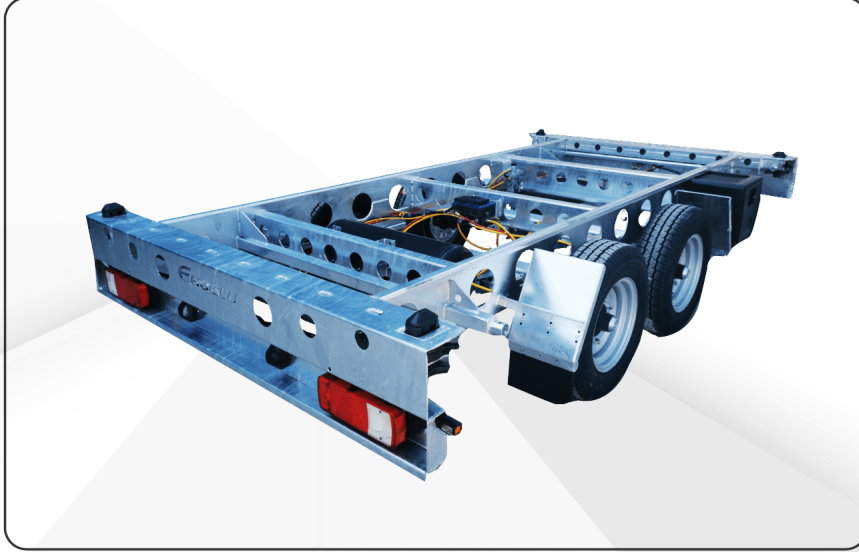

**KONTEYNER  
TAŐIYICI  
GRUBU**

**CONTAINER  
CARRIER  
SEMI TRAILER**



90 312 385 46 89

eroглуromork | bilgi@romork.com.tr | www.romork.com.tr

**EROĐLU**

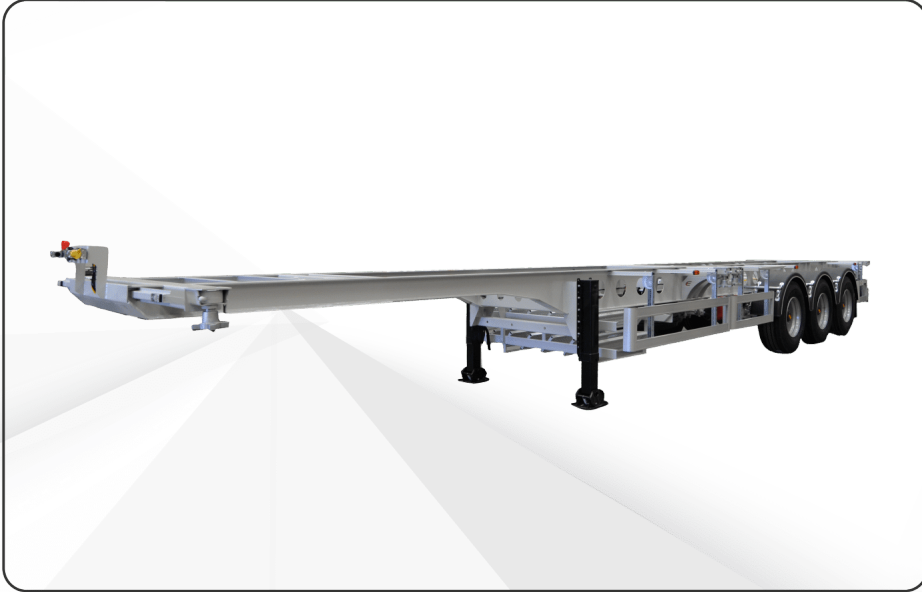



# KAMYON RÖMÖRK GRUBU

# TRUCK TRAILER



90 312 385 46 89

©0/erogluromork | bilgi@romork.com.tr | www.romork.com.tr

EROĞLU



# KAMYON RÖMORK GRUBU

# TRUCK TRAILER



90 312 385 46 89

@erogluromork | bilgi@romork.com.tr | www.romork.com.tr

EROĞLU

## ŞAŞI

- Güçlendirilmiş "I" bölümü ana çerçevesi 120/12 5 mm sac, üst ve alt düz otomatik tozaltı ark kaynağı makinesi ile kaynak
- Bu şasisler bükülmeye karşı birbirine bağlıdır.

## AKSLAR

9 ve 12 ton kapasiteli 2 ve 3 dingil kullanıldı  
TSE normlarına uygun ağır fren balataları  
Servis fren kolları var

## SÜSPANSİYON

Parabolik çift katlı Z makaslar ve amortisörler

## ÖN AKS KALDIRMA

Kabinin kontrollü ön aksı kaldırma sistemi

## LASTİKLER VE JANTLAR

385/65 R22.5 lastik

## ELEKTRİKLİ EKİPMAN

- SAE standartları ve Tuv genel yönetmeliğe uygundur
- Araçtan 7 pinli soket ile elektrik alınır. Arka park, dur, sinyal, plaka römork reflektörleri ve yanlarda turuncu uyarı aslında var

## FREN DONANIMI

- EC Standartlarına göre 71/320 frensystem.
- Otomatik fren circırları 2S / 2M EBS

## KING-PIN

- DIN 74080 standardında veya DIN 74083'te 2 "veya 3" kral pim kullanıldı

## AYAKLAR

- Çift hızlı teleskopik, mekanik taşıma ayak, 24 ton kapasite

## BOYA

- Şase ve üst yapı Yıkama + Kumlama + 2 + 1 kat Akrilik Boya boyanmak

## RENK

Ral kodu

## STANDART AKSESUARLAR

- Arka aks grubu lastiklerin kısmi kaplaması plastik çamurluklar
- 2 sac metal alet kutusu
- Plastik su pazarı
- Sepetli 1 stepne taşıyıcı
- Alüminyum bisiklet kazası alanı
- Takoz ve takoz pozisyonu

## OPSİYONEL ÖZELLİKLER

- Avrupa aks grubu ve her türlü ekipman
- NPI Bölümü ana şasi kolları
- Temel MDF, sac metal ile tamamlanmış veya bitmiş kaplama
- Alüminyum jant
- Çift stepne taşıyıcı
- Kaldırma aksı
- Kaldırma tamponu
- Yangın söndürücü ve tüp
- Kapaklara isteğe bağlı eklemeler
- İsteğe bağlı lastik markası
- İsteğe bağlı RAL renk kodları

## CHASSIS

- Reinforced "I" section main frame 120/12 5 mm sheet metal, top and bottom flat with automatic submerged arc welding machine source
- These chassis are interconnected against bending.

## Trucks Trailer

### UPPER STRUCTURE

- 9.000mm-13.600mm front straight line, inner 2550mm wide 2440mm
- With 4 or 5 covers on the sides and case mounted
- Covers are connected externally, 800mm-900mm dir
- Base consisting of a row of metal sheets and a row of wood will close
- Press placed on the base at certain intervals print "Z" sleepers are available

### CHASSIS

- Reinforced "I" section main frame 120/12 5 mm sheet metal, top and bottom flat with automatic submerged arc welding machine welding
- These chassis are interconnected against bending.

### AXLES

- 2 and 3 axles with 9 and 12 tons capacity is used
- Heavy brake pads in accordance with TSE norms
- There are service brake levers

### SUSPENSION

- Parabolic double-deck Z shears and shock absorbers

### FRONT AXLE LIFT

- Controlled front axle of the cabin lifting system

### TIRES AND RIMS

- 385/65 R22.5 tire

### ELECTRICAL EQUIPMENT

- SAE standards and Tuv general complies with regulation
- Electricity is taken from the vehicle with a 7-pin socket.
- Rear parking, stop, signal, license plate trailer reflectors and orange warning on the sides actually exist

### BRAKE HARDWARE

- 71/320 frensystem according to EC Standards.
- Automatic brake ratchets 2S / 2M EBS

### KING-PIN

- 2 "or 3" king pin in DIN 74080 standard or DIN 74083 is used

### FEET

- Double speed telescopic, mechanical transport foot, 24 tons capacity

### PAINT

- Chassis and superstructure Washing + Sandblasting + 2 + 1 coat Acrylic Paint be painted

### COLOR

Ral code

### STANDARD ACCESSORIES

- Partial coating of rear axle group tires
- plastic fenders
- 2 sheet metal tool boxes
- Plastic water market
- 1 spare wheel carrier with basket
- Aluminum bike crash site
- Chock and chock position

### OPTIONAL FEATURES

- European axle group and all kinds of equipment
- NPI Division main chassis arms
- Base MDF finished or finished with sheet metal covering
- Aluminum rim
- Double spare wheel carrier
- Lifting axle
- Lift buffer
- Fire extinguisher and tube
- Optional additions to the covers
- Optional tire brand
- Optional RAL color codes





**KAMYON  
RÖMÖRK  
GRUBU**

**TRUCK  
TRAILER**



90 312 385 46 89

©/erogluromork | bilgi@romork.com.tr | www.romork.com.tr

**EROĞLU**



# DÖNER DİNGİLLİ RÖMORK GRUBU

## TURN TABLE TRAILER



90 312 385 46 89

©/erogluromork | bilgi@romork.com.tr | www.romork.com.tr

EROĞLU





# DÖNER DİNGİLLİ RÖMORK GRUBU

## TURN TABLE TRAILER

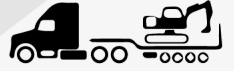

90 312 385 46 89

00/eroglumork | bilgi@romork.com.tr | www.romork.com.tr

EROĞLU

### ŞAŞI

- Güçlendirilmiş "I" bölümü ana çerçevesi 120/12 5 mm sac, üst ve alt düz otomatik tozaltı ark kaynağı makinesi ile kaynak
- Bu şaşiler bükülmeye karşı birbirine bağlıdır.

### AKSLAR

9 ve 12 ton kapasiteli 2 ve 3 dingil  
Ön aks 360 derece dönebilir  
TSE normlarına uygun ağır fren balataları  
Servis fren kolları var

### SÜSPANSİYON

Parabolik çift katlı Z makaslar ve amortisörler

### ÖN AKS KALDIRMA

Kabinin kontrollü ön aksı kaldırma sistemi

### LASTİKLER VE JANTLAR

385/65 R22.5 lastik

### ELEKTRİKLİ EKİPMAN

- SAE standartları ve Tuv genel yönetmeliğe uygundur
- Araçtan 7 pinli soket ile elektrik alınır. Arka park, dur, sinyal, plaka römork reflektörleri ve yanlarda turuncu uyarı aslında var

### FREN DONANIMI

EC Standartlarına göre 71/320 frensystem.  
• Otomatik fren circırları  
2S / 2M EBS

### KING-PIN

DIN 74080 standardında veya DIN 74083'te 2 "veya 3" kral pim kullanıldı

### AYAKLAR

- Çift hızlı teleskopik, mekanik taşıma ayak, 24 ton kapasite

### BOYA

- Şase ve üst yapı Yıkama + Kuşlama + 2 + 1 kat Akriolik Boya boyanmak

### RENK

Ral kodu

### STANDART AKSESUARLAR

Arka aks grubu lastiklerin kısmi kaplaması  
plastik çamurluklar  
2 sac metal alet kutusu  
Plastik su pazarı  
Sepetli 1 stepne taşıyıcı  
Alüminyum bisiklet kazası alanı  
• Takoz ve kama konumu

### OPSİYONEL ÖZELLİKLER

Avrupa aks grubu ve her türlü ekipman  
NPI Bölümü ana çerçeve kolları  
Temel MDF, sac metal ile tamamlanmış veya bitmiş kaplama  
Alüminyum jant  
Çift stepne taşıyıcı  
Kaldırma aksı  
Kaldırma tamponu  
• Yangın söndürücü ve tüp  
Kapaklara isteğe bağlı eklemeler  
İsteğe bağlı lastik markası  
İsteğe bağlı RAL renk kodları

### Turntable trailers

#### CHASSIS

- Reinforced "I" section main frame 120/12 5 mm sheet metal, top and bottom flat with automatic submerged arc welding machine source
- These chassis are interconnected against bending.

#### AXLES

2 and 3 axles with 9 and 12 tons capacity  
Front axle 360 degree turnable  
Heavy brake linings in accordance with TSE norms  
There are service brake levers

#### SUSPENSION

Parabolic double-deck Z shears and shock absorbers

#### FRONT AXLE LIFT

Controlled front axle of the cabin lifting system

#### TIRES AND RIMS

385/65 R22.5 tire

#### ELECTRICAL EQUIPMENT

- SAE standards and Tuv general complies with regulation
- Electricity is taken from the vehicle with a 7-pin socket.
- Rear parking, stop, signal, license plate trailer reflectors and orange warning on the sides actually exist

#### BRAKE HARDWARE

71/320 frensystem according to EC Standards.  
• Automatic brake ratchets  
2S / 2M EBS

### KING-PIN

2 "or 3" king pin in DIN 74080 standard or DIN 74083 was used

### FEET

- Double speed telescopic, mechanical transport foot, 24 tons capacity

### PAINT

- Chassis and superstructure Washing + Sandblasting + 2 + 1 coat Acrylic Paint be painted

### COLOR

Ral code

### STANDARD ACCESSORIES

Partial coating of rear axle group tires  
plastic fenders  
2 sheet metal tool boxes  
Plastic water market  
1 spare wheel carrier with basket  
Aluminum bike crash site  
• Chock and wedge position

### OPTIONAL FEATURES

European axle group and all kinds of equipment  
NPI Division main frame arms  
Base MDF finished or finished with sheet metal covering  
Aluminum rim  
Double spare wheel carrier  
Lifting axle  
Lift buffer  
• Fire extinguisher and tube  
Optional additions to the covers  
Optional tire brand  
Optional RAL color codes

**DÖNER DİNGİLLİ  
RÖMORK  
GRUBU**

**TURN TABLE  
TRAILER**

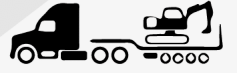

90 312 385 46 89

©/erogluromork | bilgi@romork.com.tr | www.romork.com.tr

**EROĞLU**



**DÖNER DİNGİLLİ  
RÖMORK  
GRUBU**

**TURN TABLE  
TRAILER**



90 312 385 46 89

©/erogluromork | bilgi@romork.com.tr | www.romork.com.tr

**EROĞLU**

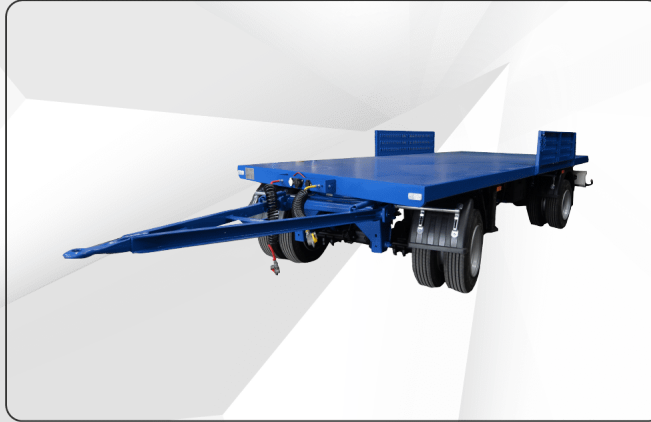



**MINI TIR**  
GRUBU

**MINI TREKKER**  
TRAILER



90 312 385 46 89

©/eroğluromork | bilgi@romork.com.tr | www.romork.com.tr

EROĞLU





90 312 385 46 89

@0/erogluromork | bilgi@romork.com.tr | www.romork.com.tr

EROĞLU

# MINİ TIR GRUBU

# MINİ TREKKER TRAILER

Hacimli ve ağır olmayan ürünleri kargoları taşımanın en akıllı yolu. Farklı treyler çözümleri ile normal trekker ve treylerlere göre daha ekonomik ve kullanımı daha kolaydır.

Iveco 70 C 15 - 35 c 15, Mercedes Sprinter 519'un dönüşümüdür, Iveco Eurocargo, Mercedes Atego, Man tTGL tipi araçlar belirli işlemlerden sonra trekker olarak modifiye edilir.

Bu araçlar yeni veya ikinci el şasi olarak temin edildikten sonra Avrupa'dan yüksek kapasiteli kompresör ve sistemler kurulum ve kamyon sınıfından traktör sınıfına dönüştürülerek araçlar tescil edilir.

İki farklı treyler türü vardır. O3 sınıfı tek ve çift aks O2 sınıfı çift aks. O3 sınıfı tek ve çift akslı treylerler büyüklerle aynıdır. Yerli ve Avrupa aksları, Domex veya ST52 sac metal ana çerçeve, tek lastik ve çift lastik, WAbco Knorr EBS, havalı süspansiyon.

O2 tipi yarı römork, Alman ALKO tarafından imal edilen havalı frenli burulma aksları kullanılarak üretilmektedir. Bu römorkların en önemli özelliği yere yakın olmaları ve satın alma maliyetlerinin diğerlerine göre çok daha düşük olmasıdır.

The smartest way to transport bulky and not heavy products and cargo. With its different trailer solutions, it is more economical and easier to use than normal trekkers and trailers.

Iveco 70 C 15 - 35 c 15 is the conversion of Mercedes Sprinter 519, Iveco Eurocargo, Mercedes Atego, Man tTGL type vehicles are modified as trekkers after certain procedures.

After these vehicles are supplied as new or second hand chassis, high-capacity compressors and systems are installed from Europe and the vehicles are registered by converting from truck class to tractor class.

There are two different trailer types. O3 class single and double axle O2 class double axle. O3 class single and double axle trailers are the same as the big ones. Domestic and European axles, Domex or ST52 sheet metal main frame, single tire and double tire, WAbco Knorr EBS, air suspension.

The O2 type semi-trailer is produced using torsion axles with air brakes manufactured by German ALKO. The most important feature of these trailers is that they are close to the ground and their purchase costs are much lower than others.





# MINİ TIR GRUBU

# MINİ TREKKER TRAILER



90 312 385 46 89

eroглуromork | bilg@romork.com.tr | www.romork.com.tr

EROĞLU





# MINİ TIR GRUBU

# MINİ TREKKER TRAILER



90 312 385 46 89

©0/erogluromork | bilgi@romork.com.tr | www.romork.com.tr

EROĞLU



**EROĞLU**

**ÖZEL AMAÇLI  
RÖMÖRK  
GRUBU**

**LIGHT  
TRAILER**





## AÇIK KASA VE PLARTFORM RÖMORKLAR

Toplam kapasite 3500 kg  
Alko torsiyon dingilli 2x1800 kg  
Alko frenli kaplinli 3500 kg  
195 75 13 C lastik ve jantlı 4+1  
ST52 malzemeden bükümlü ana şasesi  
Alüminyum rampalı 2x1  
Ön teker destek ayaklı  
Üst platform plywood yada metal  
Metal yan kapaklar

## OPEN AND SIDE HATCH TRAILERS

Total capacity 3500 kg  
2x1800 kg with alko torsion axle  
3500 kg with Alko brake coupling  
195 75 13 C with tires and rims 4 + 1  
ST52 material twisted main chassis  
Aluminum ramp 2x1  
Front wheel with support legs  
Upper platform plywood or metal  
Metal side covers



90 312 385 46 89

©/erogluromork | bilgi@romork.com.tr | www.romork.com.tr



EROĞLU



## ARAÇ TAŞIMA RÖMORKLAR

Toplam kapasite 3500 kg  
Alko torsiyon dingilli 2x1800 kg  
Alko frenli kaplinli 3500 kg  
195 75 13 C lastik ve jantlı 4+1  
ST52 malzemeden bükümlü ana şasesi  
Alüminyum rampalı 2x1  
Ön teker destek ayaklı  
Üst platform kabartmalı malzemeden

## VEHICLE TRANSPORT TRAILERS

Total capacity 3500 kg  
2x1800 kg with alko torsion axle  
3500 kg with Alko brake coupling  
195 75 13 C with tires and rims 4 + 1  
ST52 material twisted main chassis  
Aluminum ramp 2x1  
Front wheel with support legs  
Upper platform is made of embossed material

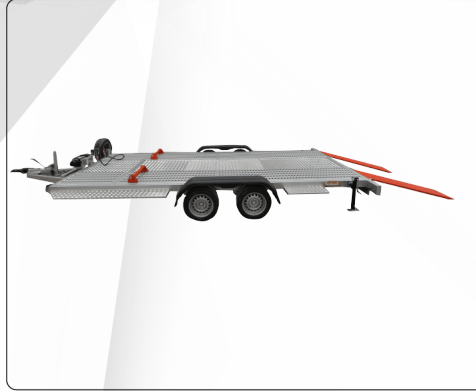
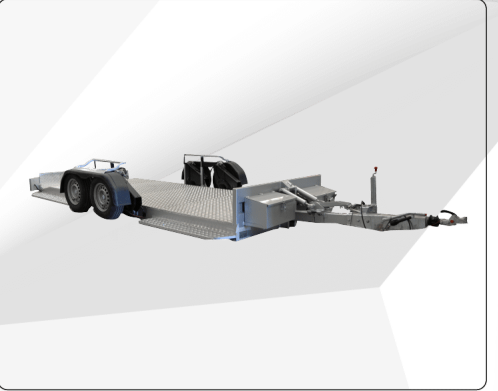
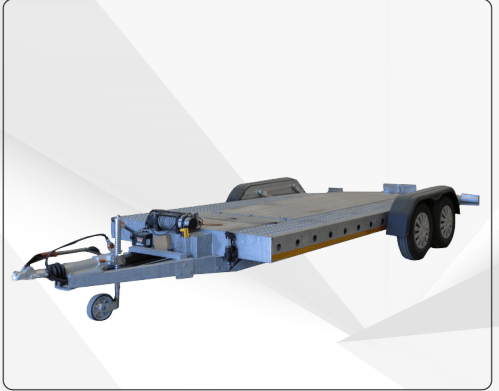
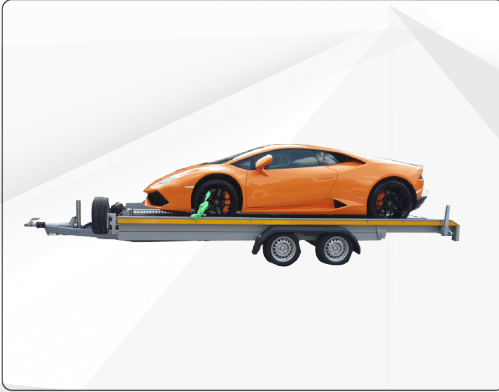

90 312 385 46 89

©/erogluromork | bilgi@romork.com.tr | www.romork.com.tr



EROĞLU

## KAPALI KASA RÖMORKLAR

Toplam kapasite 3500 kg  
Alko torsiyon dingilli 2x1800 kg  
Alko frenli kaplinli 3500 kg  
195 75 13 C lastik ve jantlı 4+1  
ST52 malzemeden bükümlü ana şasesi  
Alüminyum rampalı 2x1  
Ön teker destek ayaklı  
Üst platform plywood yada metal  
Metal yan kapaklar

## BOX TRAILERS

Total capacity 3500 kg  
2x1800 kg with alko torsion axle  
3500 kg with Alko brake coupling  
195 75 13 C with tires and rims 4 + 1  
ST52 material twisted main chassis  
Aluminum ramp 2x1  
Front wheel with support legs  
Upper platform plywood or metal  
Metal side covers



90 312 385 46 89

©/eregluromork | bilgi@romork.com.tr | www.romork.com.tr



EROĞLU



**ASKERİ RÖMORK**  
GRUBU

**MILITARY**  
TRAILER



90 312 385 46 89

@0/eroglurormork | bilgi@romork.com.tr | www.romork.com.tr

EROĞLU

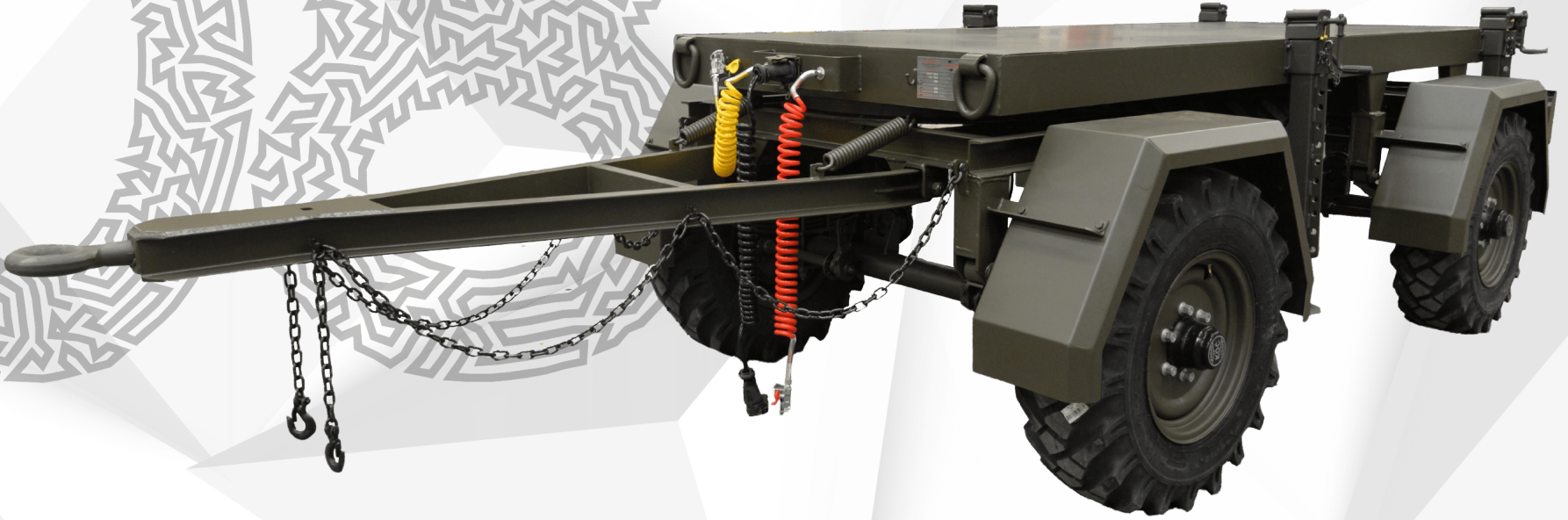





90 312 385 46 89

©/erogluromork | bilgi@romork.com.tr | www.romork.com.tr

EROĞLU

# ASKERİ RÖMORK GRUBU

# MILITARY TRAILER

Nato tip askeri römorklar  
Nato type military trailers

Npu dan ana şase  
Hava frenli  
Ön dingil 360 derece dönerli  
2-3 dingilli ve 6,9 ton kapasiteli dingiller  
üst platform sac döşeli  
12 pinli askeri elektrik kablolu  
Askeri stop lambaları , karartma lambası , iz lambaları  
ve  
plaka lambaları  
Unimog lastik ve jantlı  
Yükseklik ayarlı çeki oklu  
4 adet tonajlı yan destek ayaklı

With main chassis from npu  
With air brake  
Front axle rotates 360 degrees  
2-3 axles and 6, 9 ton capacity axles  
upper platform sheet paved  
12 pin military power cable  
Military taillights, dimming lamp, track lamps and  
license  
plate lamps



**ASKERİ RÖMORK**  
GRUBU

**MILITARY**  
TRAILER



90 312 385 46 89

©0/erogluromork | bilgi@romork.com.tr | www.romork.com.tr

EROĞLU



# ASKERİ RÖMORK GRUBU

# MILITARY TRAILER



90 312 385 46 89

©/erogluromork | bilgi@romork.com.tr | www.romork.com.tr

EROĞLU





# JENERATÖR RÖMÖRK GRUBU

# GENERATOR TRAILER



90 312 385 46 89

@0/erogluromork | bilgi@romork.com.tr | www.romork.com.tr

EROĞLU



# JENERATÖR RÖMORK GRUBU

# GENERATOR TRAILER

750 kg'dan 15.000 kg'a kadar her türlü jeneratörü taşımak için üretilmektedir. Dingil ve lastik sayısı, fren sistemi ve süspansiyon, jeneratörün ağırlığı ve kullanım şartlarına göre tasarlanır. Tip onay sertifikalı ve sertifikasız olarak üretilebilir. Tek dingil, çift dingil tandem, çift dingil rotary ve üç dingil döner tip römork sistemleri kullanılmaktadır.

It is produced to carry all kind of generators from 750 kg to 15.000 kg. The number of axles and tires, brake system and suspension are designed according to the weight of the generator and the conditions of use. It can be produced with and without type approval certificate. Single axle, double axle tandem, double axle rotary and three axle rotary type trailer systems are used.



# JENERATÖR RÖMORK GRUBU

# GENERATOR TRAILER



90 312 385 46 89

@O/eroglurormork | bilgi@romork.com.tr | www.romork.com.tr

EROĞLU





**JENERATÖR  
RÖMÖRK  
GRUBU**

**GENERATOR  
TRAILER**



90 312 385 46 89

©/aerogluromork | bilgi@romork.com.tr | www.romork.com.tr

**EROĞLU**

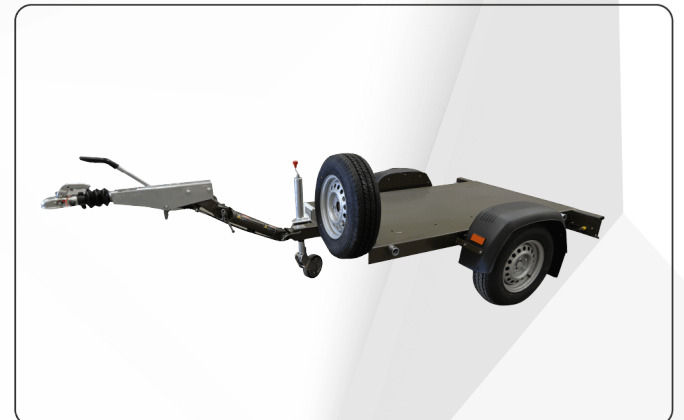

**IŞIK KULELERİ**  
GRUBU

**LIGHT**  
**TOWER**



90 312 385 46 89

©0/eroglurormark | bilgi@romark.com.tr | www.romark.com.tr



**EROĞLU**

# IŞIK KULELERİ GRUBU

# LIGHT TOWER

Gece çalışmak için gerekli olan ışığı sağlamak için ışık kuleleri kullanılır. Her türlü şantiye, yol ve hava şartlarında kullanılabilirler. Kullanılacak yere göre tasarlanır ve üretilir. Hidrolik ve mekanik olmak üzere ikiye ayrılır. Yerden 6 ile 9 metre arasında bir yüksekliğe ulaşabilir. Yanlarda açılan dört yan destek ayağı, salınım ve rüzgar etkisini azaltır. Kulenin ucuna takılan lambalar mekanik olarak veya aşağıdan bir joystick kolu ile 340 derece döndürülebilir. İki tür hidrolik olan vardır. Tamamen hidrolik ve hidromekanik. Tam hidrolik olanlarda, kule direğinin içinde çift etkili teleskopik bir hidrolik asansör vardır. Hidromekanik olanında ilk bom hidrolik olarak tetiklenir ve bu reaksiyonla diğer bomlar halatlar sayesinde açılır. Mekanik kulelerde kaldırma manuel bir el vinci ile yapılır.

Light towers are used to provide the light necessary for working at night. They can be used in all kinds of construction sites, roads and weather conditions. It is designed and produced according to the place to be used. It is divided into hydraulic and mechanical. It can reach a height between 6 and 9 meters from the ground. Four side support legs, which are opened on the sides, reduce the swing and wind effect. The lamps attached to the end of the tower can be rotated mechanically or from below with a joystick arm by 340 degrees. There are two types of hydraulic ones. Fully hydraulic and hydromechanical. In the fully hydraulic ones, there is a double-effect telescopic hydraulic lift inside the tower mast. In the hydro-mechanical one, the first boom is triggered hydraulically and with this reaction, the other booms are opened thanks to the ropes. Lifting in mechanical towers is done with a manual hand winch





# İŞIK KULELERİ GRUBU

# LIGHT TOWER



90 312 385 46 89

©0/erogluromork | bilgi@romork.com.tr | www.romork.com.tr

EROĞLU



# İŞIK KULELERİ GRUBU

# LIGHT TOWER



90 312 385 46 89

©/eroглуromork | bilgi@romork.com.tr | www.romork.com.tr

EROĞLU



# Belgeler / Homologation

- **01 ONE AXLE – 01 TEK DİNGİL**
- **02 ONE AXLE TORSION – 02 TEK DİNGİL**
- **02 TWO AXLE TANDEM TORSION – 02 ÇİFT TANDEM DİNGİL**
- **02 TWO AXLE AIR BRAKE LEAF SPRING FULL TRAILER – 02 CİFT DİNGİL HAVA FRENLİ MAKASLI SÜSPANSİYONLU**
- **02 TWO AXLE MECHANICAL BRAKE FULL TRAILER – 02 MEKANİK FREN DÖNER DİNGİLLİ**
- **02 ONE AXLE MECHANICAL BRAKE LEAF SPRING – 02 TEK DİNGİL MEKANİK FRENLİ MAKASLI**
- **02 TWO AXLE MECHANICAL BRAKE LEAF SPRING TANDEM – 02 MEKANİK FREN MAKASLI SUSPANSİYON TANDEM**
- **02 TWO AXLE AIR BRAKE LEAF SPRING TANDEM – 02 HAVALI FRENLİ MAKASLI TANDEM**
- **02 TANDEM YARI RÖMORK – 02 TANDEM SEMİ TRAILER**
- **03 TWO AXLE TORSION AIR BRAKE TANDEM – 03 ÇİFT DİNGİL KAMYON RÖMORKU**
- **03 ONE AXLE SEMİ TRAILER – 03 TEK DİNGİL YARI RÖMORK**
- **03 TWO AXLE SEMİ TRAILER – 03 ÇİFT DİNGİL YARI RÖMORK**
- **03 TWO TORSION AXLES ABS – 03 TORSİYON DİNGİL KAMYON RÖMORKU**
- **04 ONE AXLE SEMİ TRAILER – 04 TEK DİNGİL YARI RÖMORK**
- **04 TWO AXLE SEMİ TRAILER – 04 ÇİFT DİNGİL YARI RÖMORK**
- **04 THREE AXLE SEMİ TRAILER – 04 3 DİNGİL YARI RÖMORK**
- **04 TURNTABLE FULL TRAILER – 04 TAM RÖMORK**
- **THREE , FOUR , FIVE AXLE LOW BED – 2 ,3 ,4, 5 DİNGİL LOWBED YARI RÖMORK**



 **90 312 385 46 89**

 [/erogluromork](#) | [bilgi@romork.com.tr](mailto:bilgi@romork.com.tr) | [www.romork.com.tr](http://www.romork.com.tr)

